

C 1507

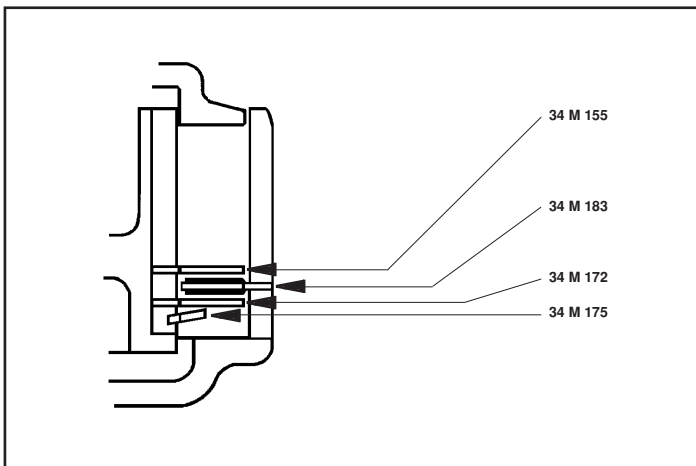
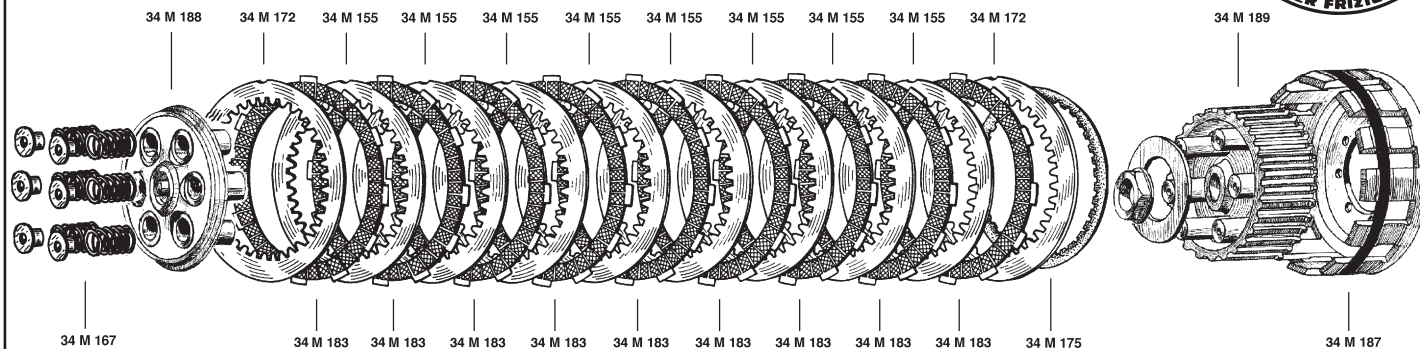

MATRICOLA	DESCRIZIONE
C 1507	Gruppo completo modificato
34 M 187	Coppa
34 M 189	Innesto
34 M 175	Molla di modulazione carico
34 M 172	Disco acciaio
34 M 183	Disco guarnito
34 M 155	Disco acciaio
34 M 188	Spingidischi
34 M 167	Molla

C 1514 + C 1515

DUCATI SPECIAL CLUTCHES

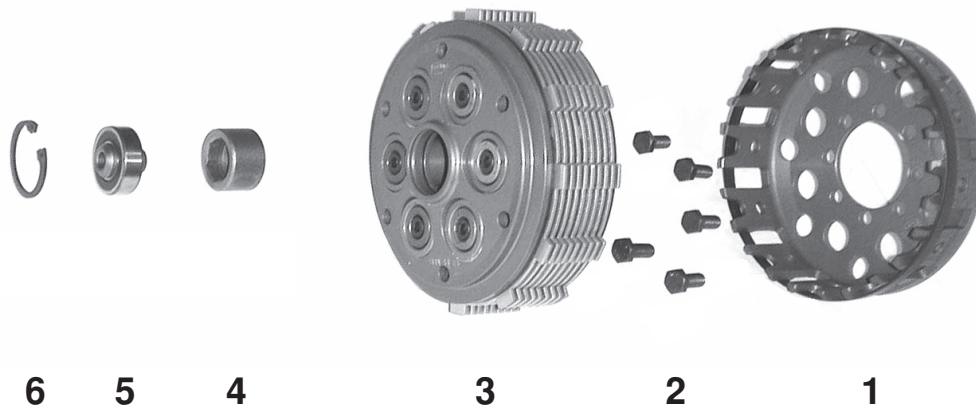

DIRECTIONS FOR USE

Set up the clutch components in sequence, starting from 1.

NOTE

When dismantling the previous clutch assembly, carefully remove any possible trace of adhesive from shaft and primary gear. Before setting up the new clutch, put a drop of thread adhesive on the tips of the eight screws 2.

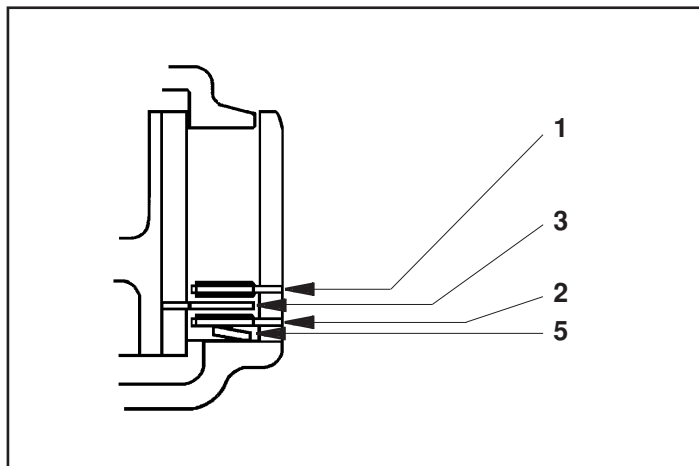
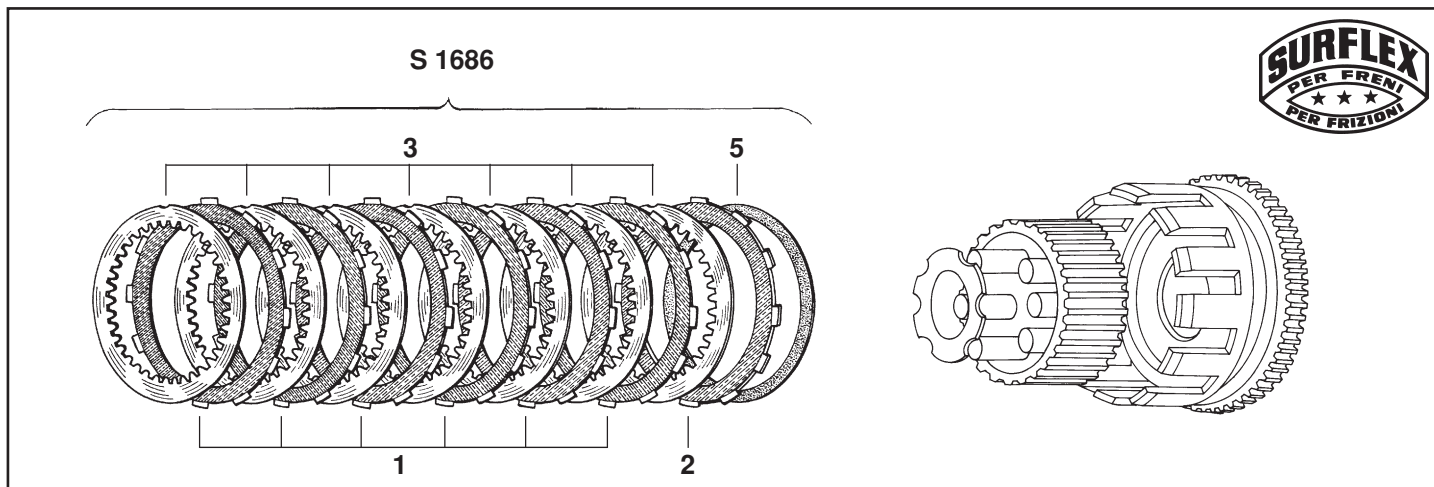

MODIFICA

a secco
spess. 33,3 mm

Serie composta da:
6 dischi sinterizzati (1)
1 disco sinterizzato da una parte (2)
7 dischi acciaio (3)
1 molla modulazione carico (5)

UP-GRADE KIT
33,3 mm thick
to work dry

S 1687

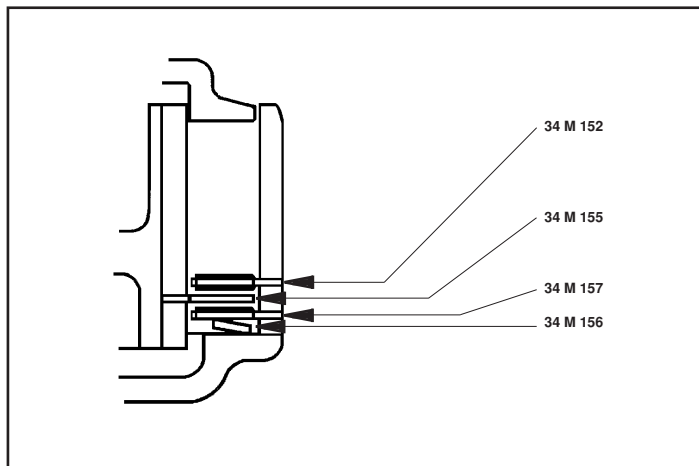
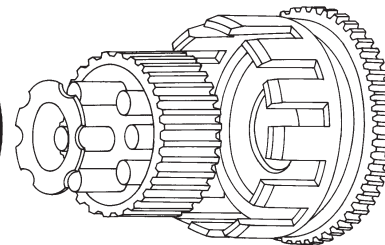
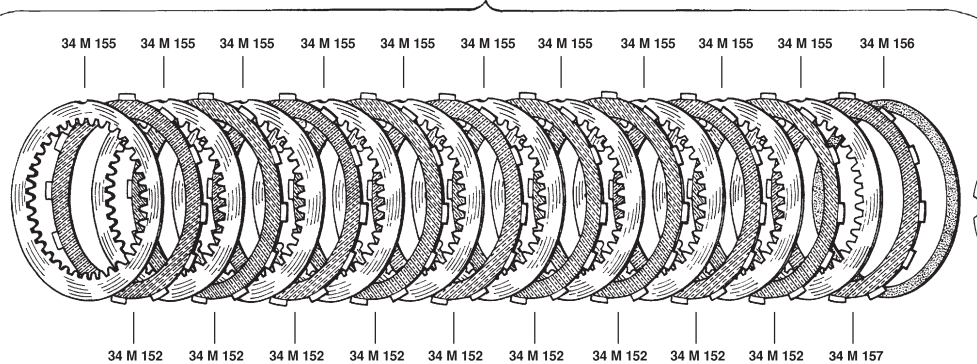

MATRICOLA	DESCRIZIONE
<p>S 1687 a secco spess. 39,8 mm</p>	<p>Serie composta da: 9 articolo 34 M 152 1 articolo 34 M 157 10 articolo 34 M 155 1 articolo 34 M 156</p>

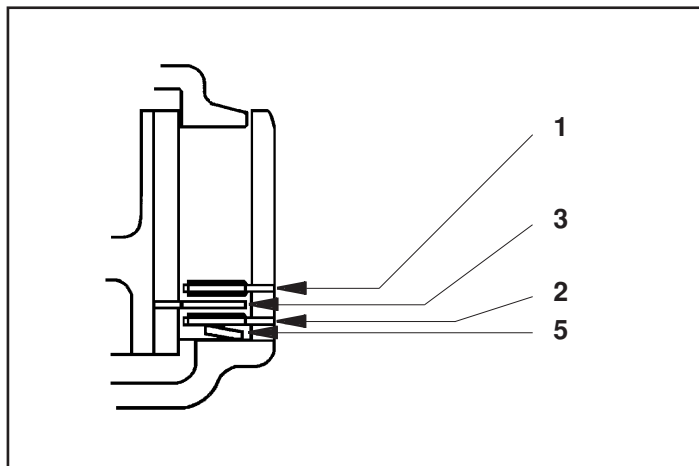
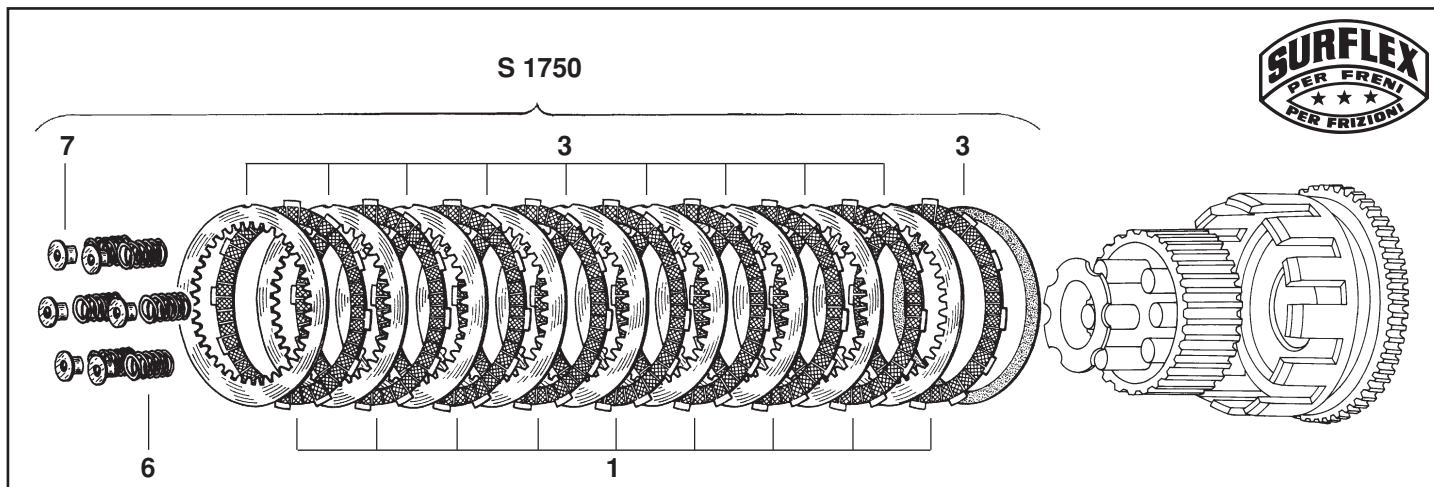

MODIFICA

a secco
spess. 39,7 mm

UP-GRADE KIT
39,7 mm thick
to work dry

Serie composta da:

- 1 molla modulazione carico (5)
- 1 disco guarnito da una parte (2)
- 8 dischi guarniti (1)
- 9 dischi acciaio (3)
- 6 molle chiusura frizione (6)
- 6 bicchierini (7)

S 1815

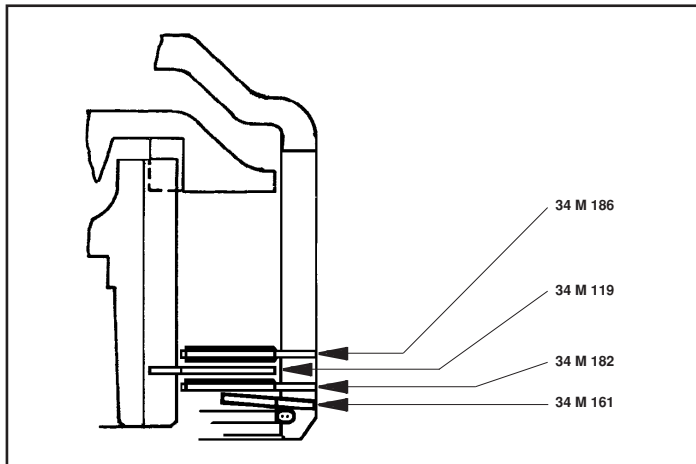
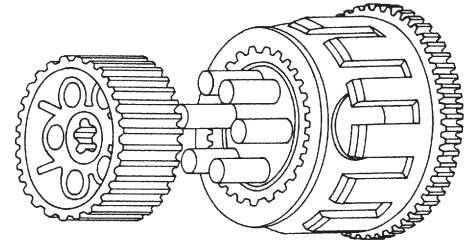
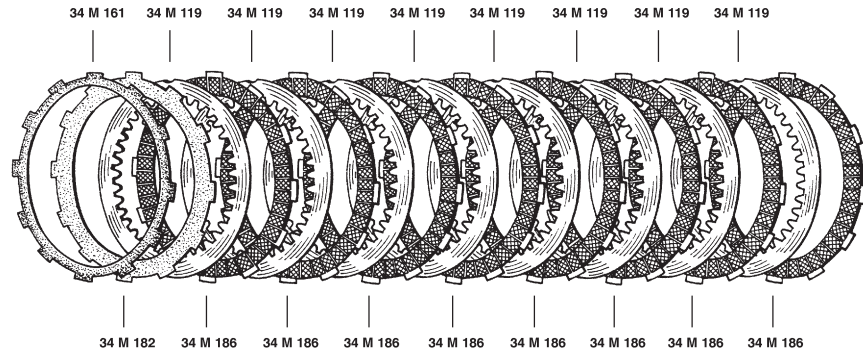

MATRICOLA	DESCRIZIONE
S 1815 in olio spess. 35,7 mm	Serie composta da: 8 articolo 34 M 186 1 articolo 34 M 182 8 articolo 34 M 119 1 articolo 34 M 161



S 1817

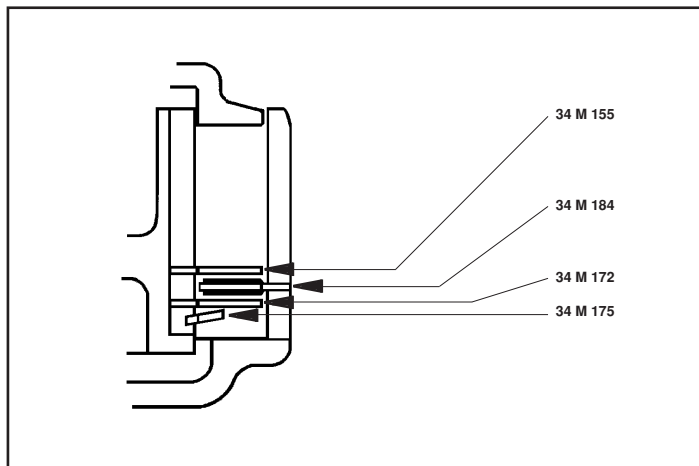
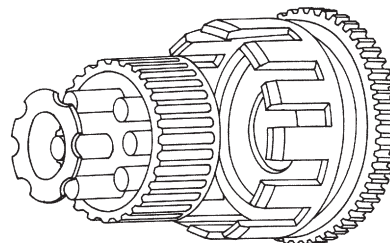
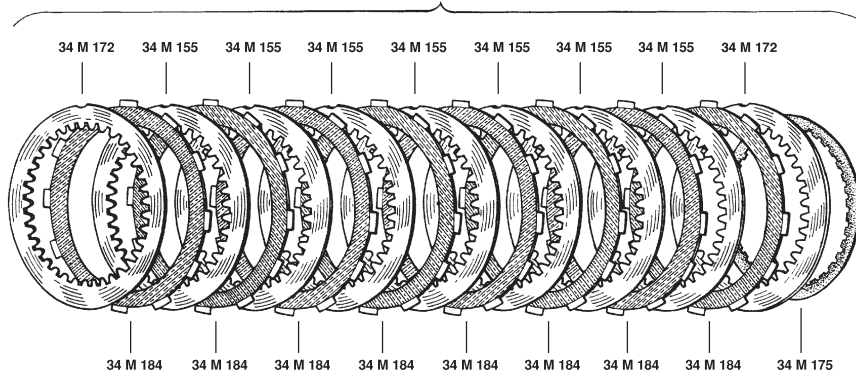

MATRICOLA	DESCRIZIONE
<p>S 1817 a secco spess. 38 mm</p>	<p>Serie composta da: 8 articolo 34 M 184 7 articolo 34 M 155 2 articolo 34 M 172 1 articolo 34 M 175</p>

S 1908

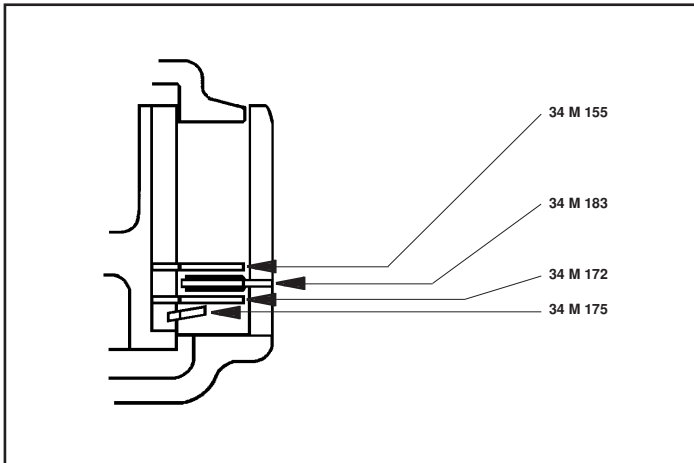
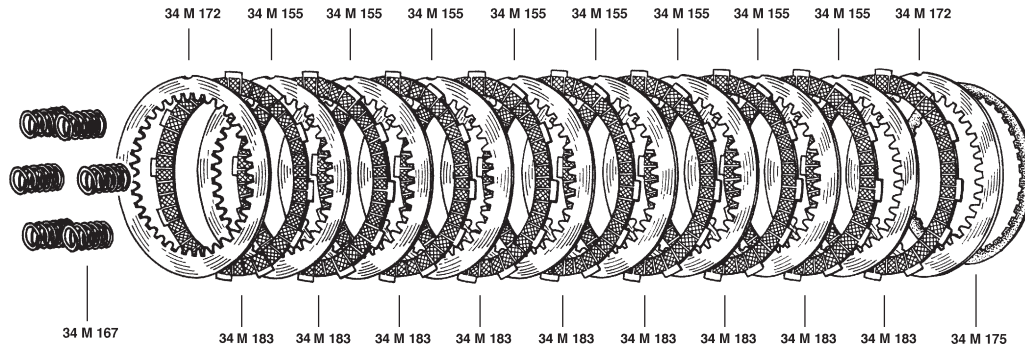

MATRICOLA	DESCRIZIONE
S 1908	<p>Serie composta da:</p> <ul style="list-style-type: none"> 9 articolo 34 M 183 8 articolo 34 M 155 2 articolo 34 M 172 1 articolo 34 M 175 6 articolo 34 M 167

S 1958

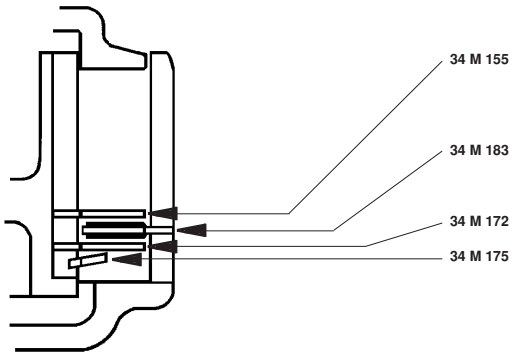
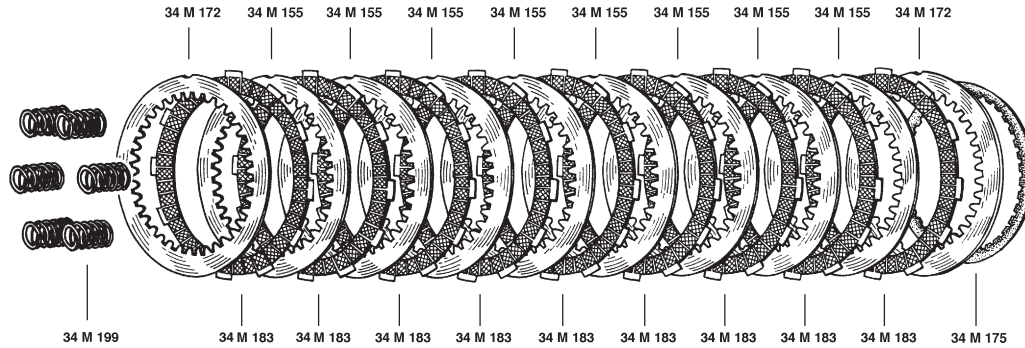

MATRICOLA	DESCRIZIONE
S 1958	Serie composta da: 9 articolo 34 M 183 8 articolo 34 M 155 2 articolo 34 M 172 1 articolo 34 M 175 6 articolo 34 M 199



S 1964

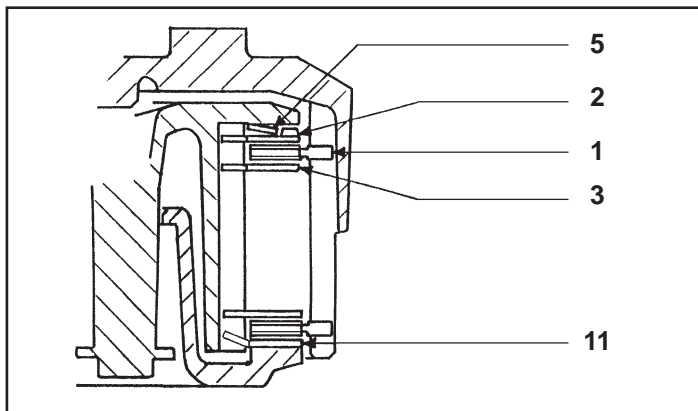
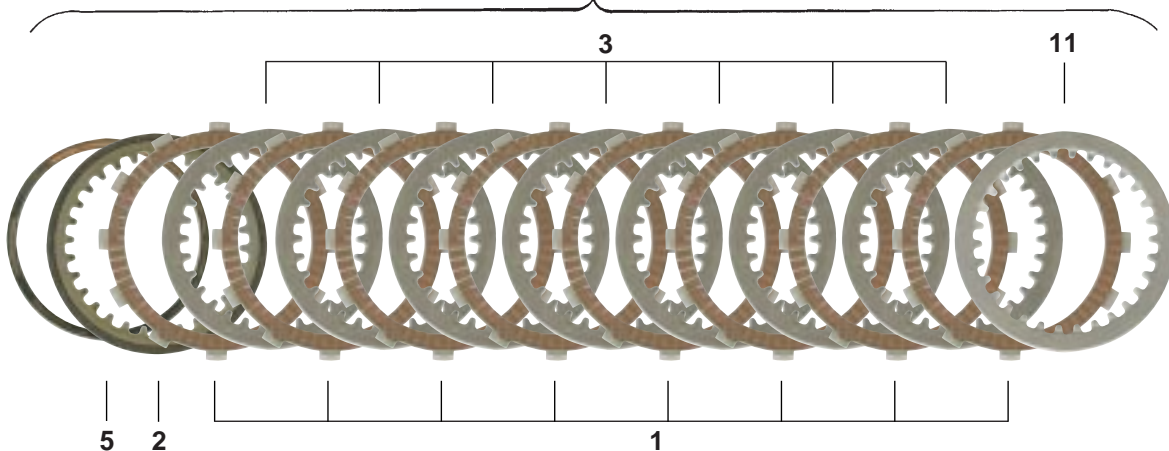
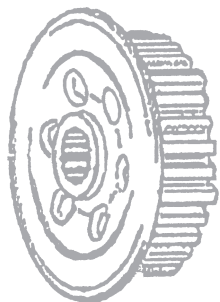

MODIFICA

Serie composta da:

1 molla modulazione carico **(5)**

1 disco guarnito da una parte **(2)**

8 dischi guarniti **(1)**

7 dischi acciaio **(3)**

1 disco acciaio a denti piegati **(11)**



S 1981

3

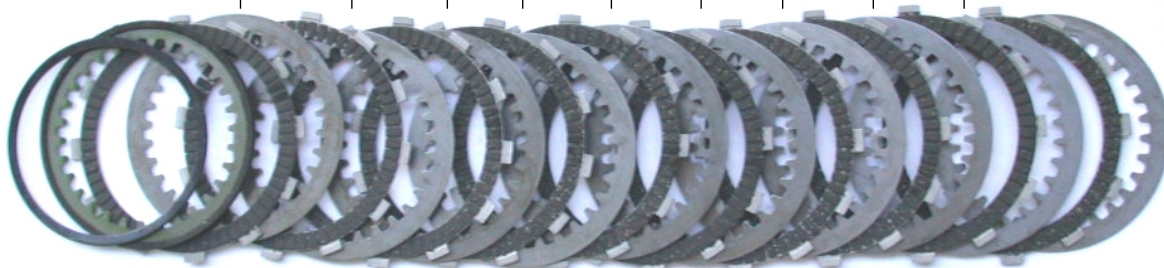
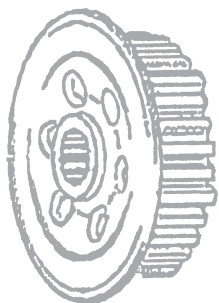

5

2

1

11

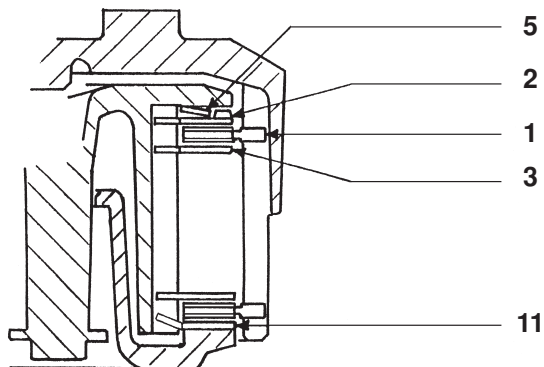

MODIFICA

Serie composta da:

1 molla modulazione carico (5)

1 disco guarnito da una parte (2)

10 dischi guarniti (1)

9 dischi acciaio (3)

1 disco acciaio a denti piegati (11)

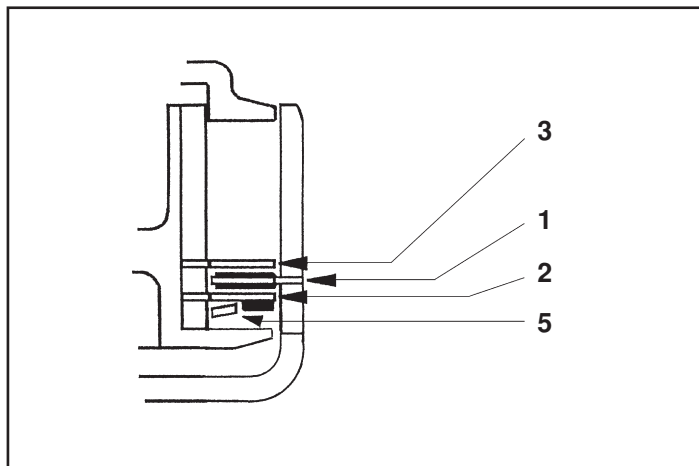
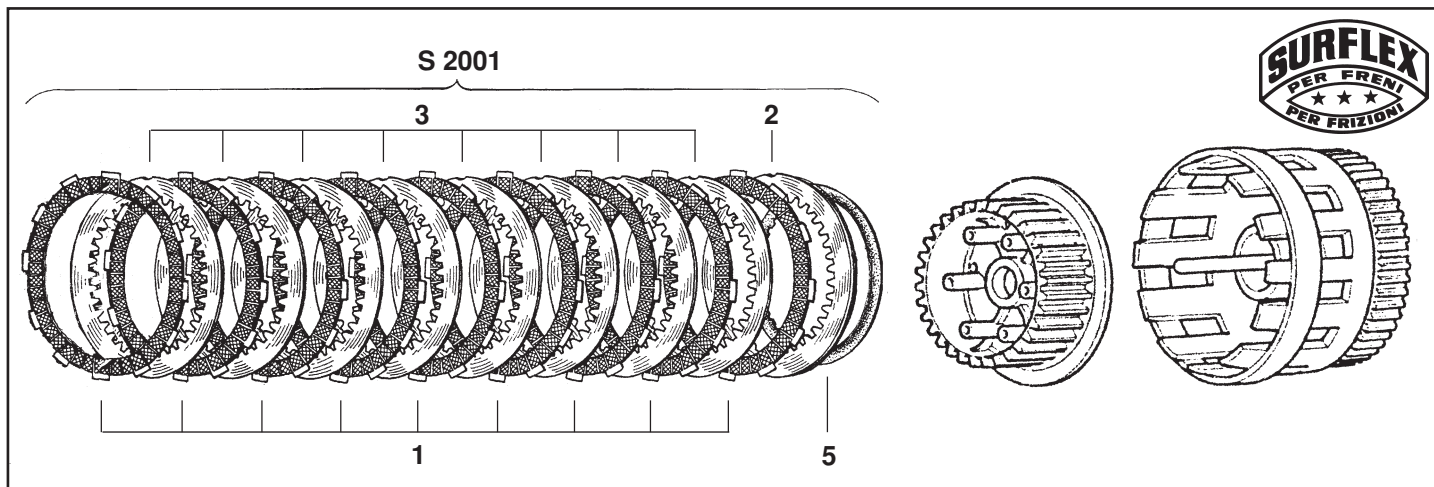

MODIFICA

in olio
spess. 43,5 mm

UP-GRADE KIT
43,5 mm thick
to work in oil
bath

Serie composta da:
9 dischi guarniti (1)
8 dischi acciaio (3)
1 disco guarnito da una parte (2)
1 molla modulazione carico (5)

LE FRIZIONI SURFLEX ANTISALTELLAMENTO

Il sistema antisaltellamento è un dispositivo che consente di migliorare il comfort e la stabilità dei motocicli, evitando che la ruota posteriore perda aderenza durante le staccate e i bruschi cambi di marcia in decelerazione.

Trova la sua applicazione su veicoli sia da strada che fuoristrada dotati di grossi motori mono e bicilindrici a quattro tempi, dove gli effetti del freno motore si fanno sentire maggiormente.

Come lavora il sistema antisaltellamento brevettato da SURFLEX ?

Nel caso di forte decelerazione, oltre una soglia prestabilita, una camma a profilo elicoidale costringe rapidamente un piatto mobile a premere dall'interno sullo spingidischi, togliendo alla frizione gran parte del carico, proporzionalmente alla decelerazione.

L'effetto immediato è un temporaneo slittamento che separa parzialmente il motore dalla trasmissione, salvaguardando quest'ultima da notevoli sollecitazioni.

Queste i principali vantaggi del sistema antisaltellamento SURFLEX :

- è facile da montare
- non richiede manutenzione, anche nelle applicazioni a secco, perché tutti i componenti sono realizzati in acciai legati trattati termicamente
- per funzionare correttamente non necessita di particolari attenzioni, se non quella di accertarsi periodicamente che lo spessore del pacco dischi non si riduca oltre 1,5 mm rispetto al valore iniziale tarato in fabbrica
- può essere adeguato a eventuali esigenze specifiche, semplicemente sostituendo le molle di richiamo del piatto mobile (alloggiate all'interno delle molle chiusura frizione) con altre molle di carico adeguato.
- Tale operazione si può effettuare senza aprire la frizione, né toglierla dalla sua sede, perché queste molle sono accessibili dall'esterno, svitando le viti dello spingidischi senza attrezzi particolari.

THE SURFLEX ANTI-HOP CLUTCH

Anti-hop clutches have been developed to improve motorcycle comfort and stability when speed is drastically reduced, especially in four stroke big singles and twins both for road and off-road use.

In these cases the effects of engine braking are more evident, affecting mostly the rear wheel, which tends to loose its grip when throttling back or suddenly shifting down, for instance before a bend.

Let's see how our patented anti-hop clutch works.

During severe deceleration, beyond a pre-established load, a snail cam rapidly pushes a slipping plate against the inside of the pressure plate, so unloading the clutch in proportion to the deceleration.

The immediate effect is temporary clutch slip, partially disconnecting the transmission from the engine, and protecting the transmission from excessive stress.

Main features of our anti-hop clutch:

- *easy to fit*
- *no maintenance required, even when working dry, as all components are made with hardened alloy steel.*
- *no need for particular care, other than a periodic check of the total thickness of the disc pack, which should not reduce by more than 1,5 mm from the initial value set in our factory*
- *quick and easy to adjust to suit individual requirements: only the slipping plate springs have to be replaced. Without dismantling the clutch from its mounting, they can easily be reached inside the clutch springs, by simply screwing out the pressure plate screws.*
- *no special tool required for adjustment*

BENELLI TNT



Gruppo condotto con antisaltellamento *Plate pack complete with anti-hop device*

10 M 191/C

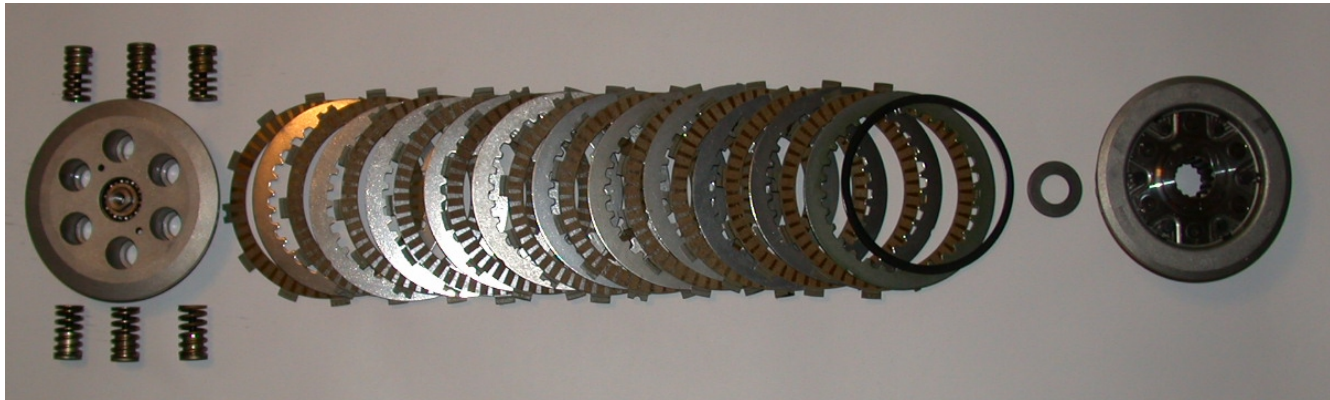

ISTRUZIONI DI MONTAGGIO

Montare i componenti nella sequenza indicata nella foto

NOTA: Smontata la frizione da sostituire, rimuovere accuratamente eventuali residui di adesivo dall'albero e dalla corona. Indi mettere una goccia di adesivo per filetti sulle viti della frizione nuova.

FITTING INSTRUCTIONS

Set up the clutch components in sequence as shown above.

NOTE: *When dismantling the previous clutch assembly, carefully remove any residual trace of adhesive from shaft and primary gear. Before setting up the new clutch, put a drop of thread adhesive on the tips of the screws.*